

SURFACE DEFORMATION DURING THE EARTHQUAKE CYCLE FOR A LAYERED VISCO-ELASTIC CRUST

Eligiusz W. Postek¹, Greg A. Houseman¹ and Peter K. Jimack²

School of Earth and Environment, Institute of Geophysics and Tectonics¹,
School of Computing², University of Leeds, LS2 9JT Leeds, UK
earewp,eargah@earth.leeds.ac.uk; pkj@comp.leeds.ac.uk



UNIVERSITY OF LEEDS

Abstract

The total deformation is modelled as a combination of viscous, linear elastic and nonlinear elastic effects and a numerical investigation into these effects is carried out. The geometrically nonlinear effects are included by taking into account the nonlinear part of the elastic strain tensor and the problem is solved assuming finite strains.

The examples considered concern displacements applied along the fault and observations of the vertical displacements at the surface.

The problem is described in the updated Lagrangian frame and the finite element system is solved using the Newton-Raphson technique. The calculations are performed using a newly developed visco-elastic version of the program "Oregon". We examine a conceptual 3D model in which a surface traction applied to a vertical fault causes vertical displacement of the upper surface of a crustal block.

Problem formulation

The mechanical problem is treated as visco-elastic in nature, with the assumption of finite strains. The problem is described in the Updated Lagrangian frame. We use the finite element technique. The FE discretized nonlinear incremental static equation of equilibrium, assumed to be fulfilled at the end of each step, is of the form

$$\left(\int_{\Omega} \mathbf{B}^T \mathbf{t} \mathbf{B} d\Omega \right) \Delta \mathbf{q} + \int_{\Omega} \mathbf{B}^T \Delta \mathbf{S} d\Omega = \int_{\Omega} \mathbf{N}^T \Delta \mathbf{f} d\Omega + \int_{\partial\Omega_t} \mathbf{N}^T \Delta \mathbf{t} d(\partial\Omega_t)$$

Here $\Delta \mathbf{q}$ is the displacement increment, $\Delta \mathbf{S}$ is the stress increment, $\Delta \mathbf{f}$ is the body forces increment, $\Delta \mathbf{t}$ is the traction increment, and \mathbf{N} is the set of shape functions.

The linear and nonlinear operators \mathbf{B} and $\hat{\mathbf{B}}$ relate linear and nonlinear parts of the Green Lagrange strain tensor with the displacement increment $\Delta \mathbf{q}$ and \mathbf{t} is the Cauchy stress matrix of the form

$$\mathbf{t} = \begin{bmatrix} t_{xx} & t_{xy} & t_{xz} \\ t_{xy} & t_{yy} & t_{yz} \\ t_{xz} & t_{yz} & t_{zz} \end{bmatrix}$$

To integrate the constitutive relations we use the co-rotational formulation. The essential point of the algorithm is the rotation of the deformation increment $\Delta \mathbf{D}$ to the un-rotated configuration using the rotation matrix \mathbf{R} which is obtained from the polar decomposition of the deformation gradient $\mathbf{F} = \mathbf{V}\mathbf{R} = \mathbf{R}\mathbf{U}$, $\Delta \mathbf{d} = \mathbf{R}^T \Delta \mathbf{D} \mathbf{R}$.

Stress calculation procedure:

- Compute deformation gradient

$$\mathbf{F}_{t+\Delta t}^i = \frac{\partial(\mathbf{X} + \mathbf{u}_{n+1}^i)}{\partial \mathbf{X}}$$

- Compute polar decomposition

$$\mathbf{F}_{t+\Delta t}^i = \mathbf{R}_{t+\Delta t}^i \mathbf{U}_{t+\Delta t}^i$$

- Compute deformation increment over the step

$$\Delta \boldsymbol{\varepsilon}^i = \mathbf{B}_{t+\Delta t}^i (\mathbf{u}_{t+\Delta t}^i)$$

- Obtain tensor form of the deformation $\Delta \mathbf{D}$ using $\Delta \boldsymbol{\varepsilon}$ increment and perform the transformation to the un-rotated configuration

$$\Delta \mathbf{d}^i = \mathbf{R}_{t+\Delta t}^{iT} \Delta \mathbf{D}^i \mathbf{R}_{t+\Delta t}^i$$

- Perform integration of the constitutive model where the stress depends on history variables $\boldsymbol{\gamma}$

$$\boldsymbol{\sigma}_{t+\Delta t}^{u(i)} = \boldsymbol{\sigma}_{t+\Delta t}^{u(i)}(\boldsymbol{\sigma}_t, \boldsymbol{\gamma}_t, \Delta \mathbf{d}^i)$$

- Transform the stress to the true Cauchy stress at the end of the step

$$\boldsymbol{\sigma}_{t+\Delta t} = \mathbf{R}_{t+\Delta t} \boldsymbol{\sigma}_{t+\Delta t}^u \mathbf{R}_{t+\Delta t}^T$$

Constitutive model:

Linear visco-elastic generalized Maxwell model

The stress increment depends on the stresses and relaxation function and bulk modulus

$$\Delta \mathbf{S} = \mathbf{D}^{const}(\mathbf{S}, G, K) \Delta \boldsymbol{\varepsilon}$$

The relaxation function takes the form

$$G(t) = G_o + \sum_{i=1}^n G_i \exp\left(\frac{-t}{\lambda_i}\right)$$

k_n , λ_n are the spring stiffnesses and relaxation times (uni-axial case)

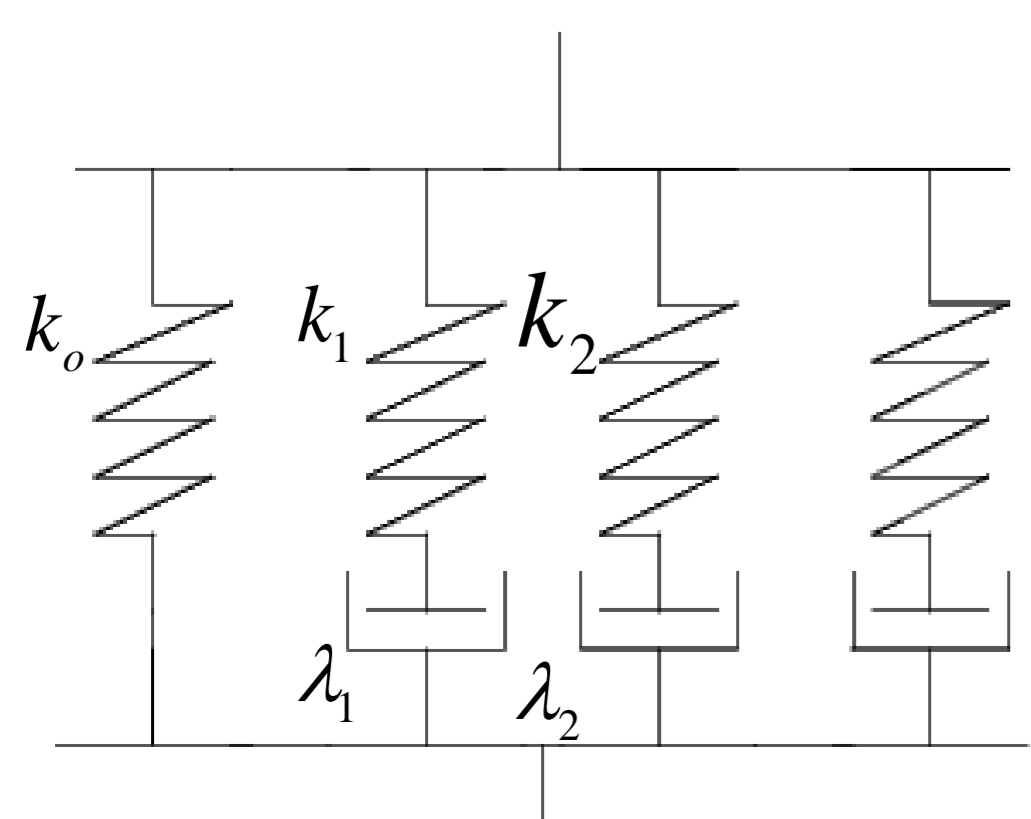

Examples

$$\varepsilon_z = 0.1(1 - 0.9 \exp(-t/10))$$

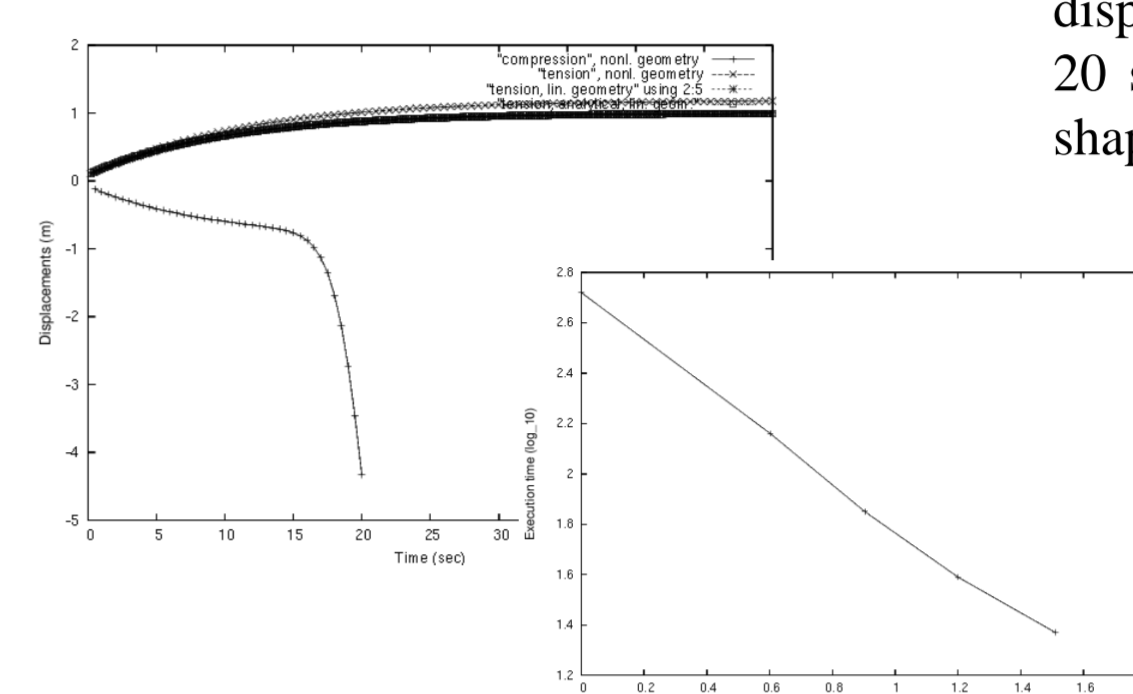
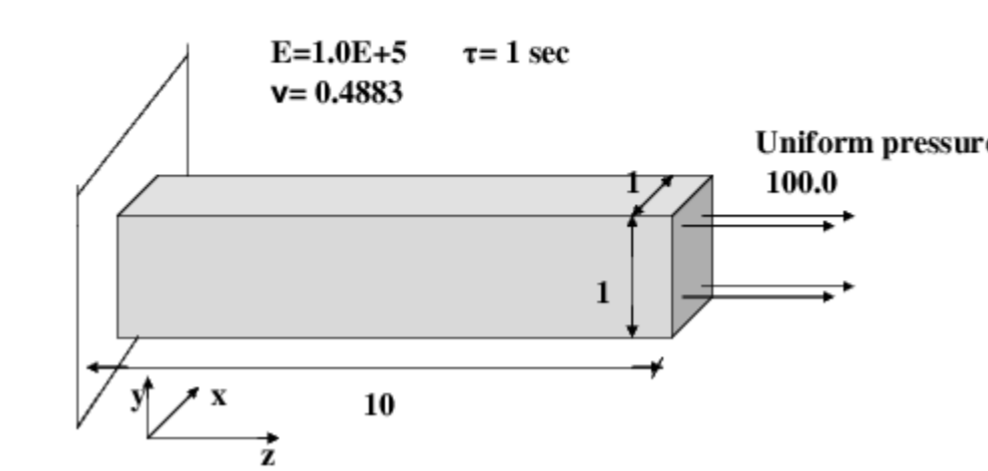

Because of non-linear geometrical effects the cantilever undergoes 20% higher 'z' displacements in tension and it buckles after 20 sec when in compression. The buckled shape is presented.

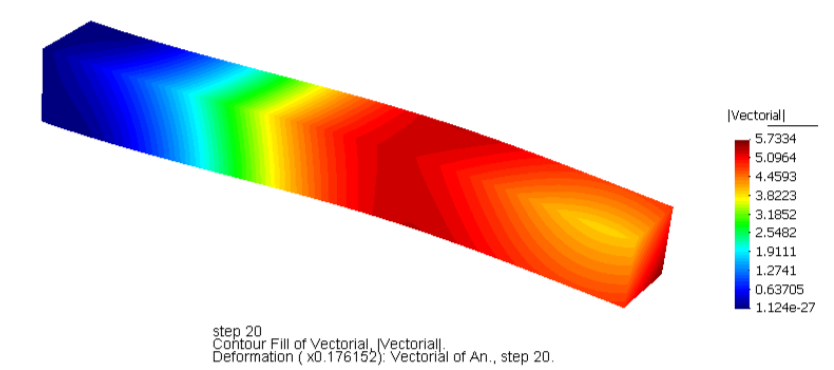

A simple geometrical model of a cantilever (fixed at $z=0$ in z direction), with a known linear visco-elastic analytical solution, is compared against the FEM model that is discretized with 13824 tetrahedra (10 nodes). The fine discretization is undertaken to evaluate the speed-up effect when solved in parallel. The scaling effect is shown above as well.

We investigate a model of a fault between two crustal blocks. Because of relative movement of the crustal blocks in the contact zones patches of load (tractions) appear. This model imposes such tractions on a single block. This action causes deformation on the surface. This deformation can be monitored by observations of the GPS points.

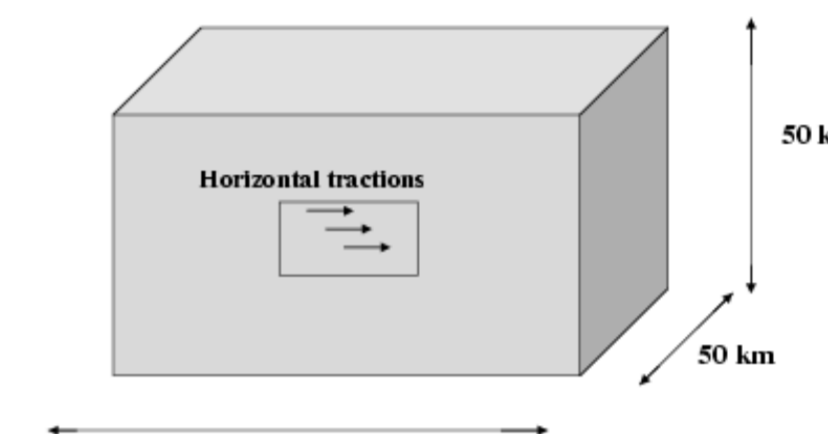
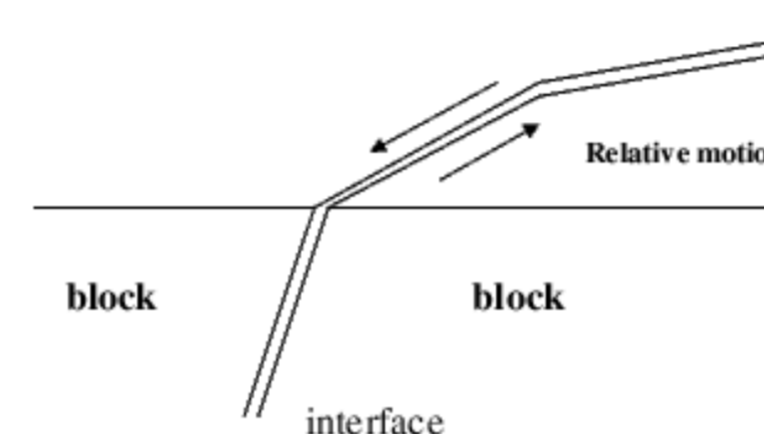

$E = 1.0E+11 \text{ N/m}^2$
 $\nu = 0.25$
 $\text{Emu} = 0.901, 0.601$
Relaxation time = $6.048E+5 \text{ sec}$

Observing the displacement pattern we may note that the surface is deformed above the region where the load patch is applied, simulating the action of the neighbouring crustal block.

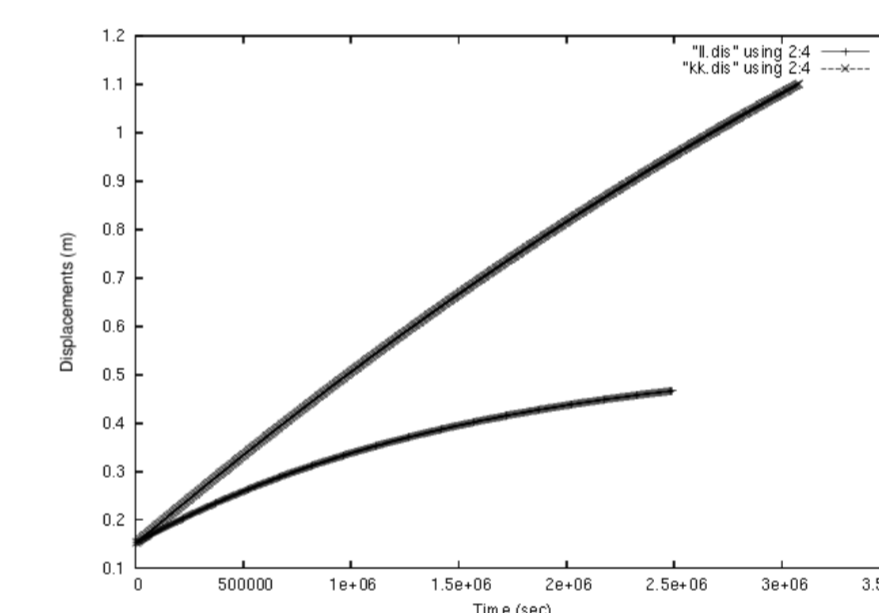
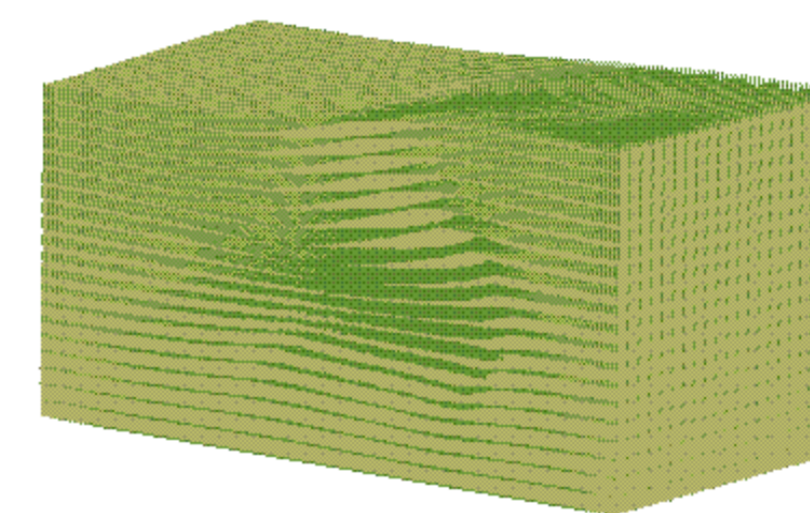

This figure presents dependence of the vertical deformation of a point on the surface on time for two different ratios of the shear moduli (Emu). The higher ratio gives results closer to the Maxwell model characteristics

The view from above the block shows that the deformation of the block can have quite characteristic features, namely there can appear a small depression and a subsequent small hill close to the edge of the fault (Figure on the left shows vertical deformation, blue is negative, figure on the right shows horizontal deformation).

Max vertical deformation 0.27 m

Max horizontal deformation 0.11 m

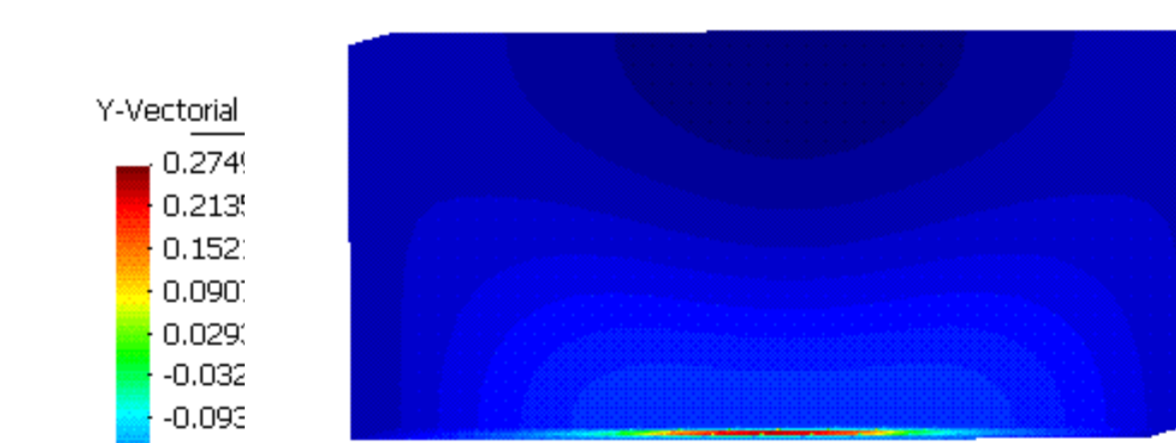
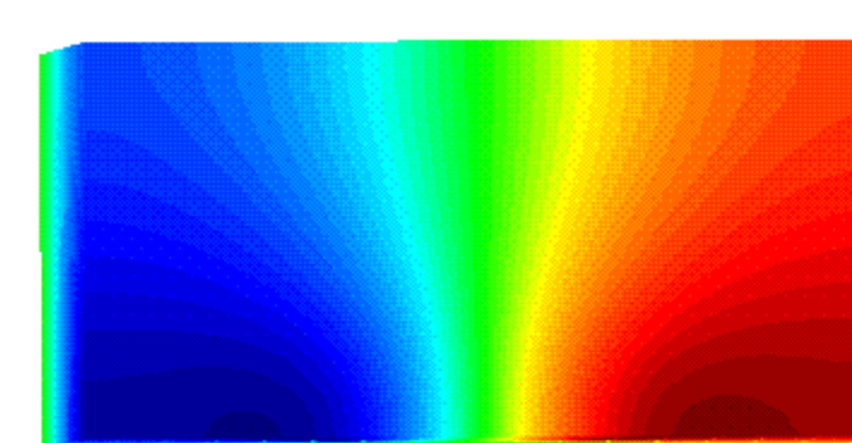

This simulation employed a material of 1 week relaxation time and was performed for 2 weeks (using 38400 tetrahedra, 32 CPUs, IBM Power5, University of Edinburgh)

We consider a 3 layer system with weak mid layer (the Young modulus is two times smaller than the neighbouring layers, the relaxation time is $8.048E+5 \text{ sec}$). The ratios of the shear moduli are 0.1, 0.6 and 0.9. The horizontal and vertical deformations are shown in the figures below.

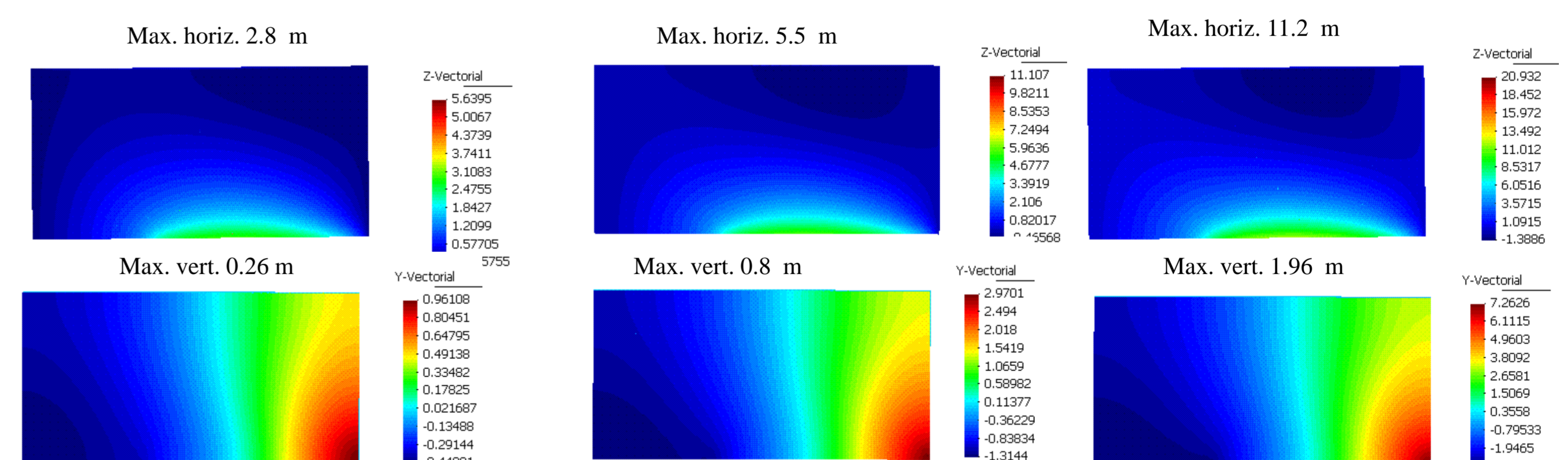

The behaviour of the layered system is qualitatively different from the homogenous one. The horizontal and vertical deformation patterns are unsymmetric. The maximum horizontal and vertical deformations depends strongly on the shear moduli ratio.

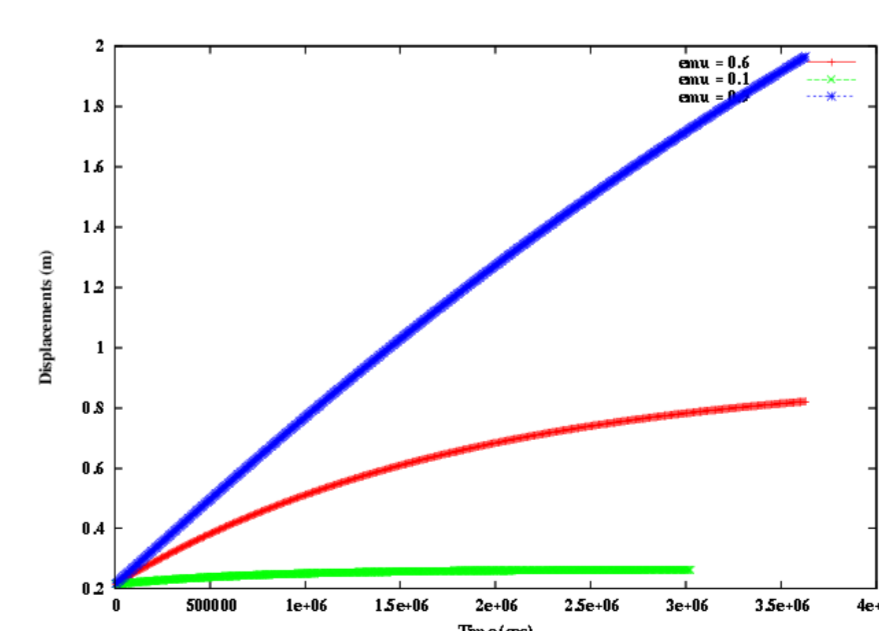
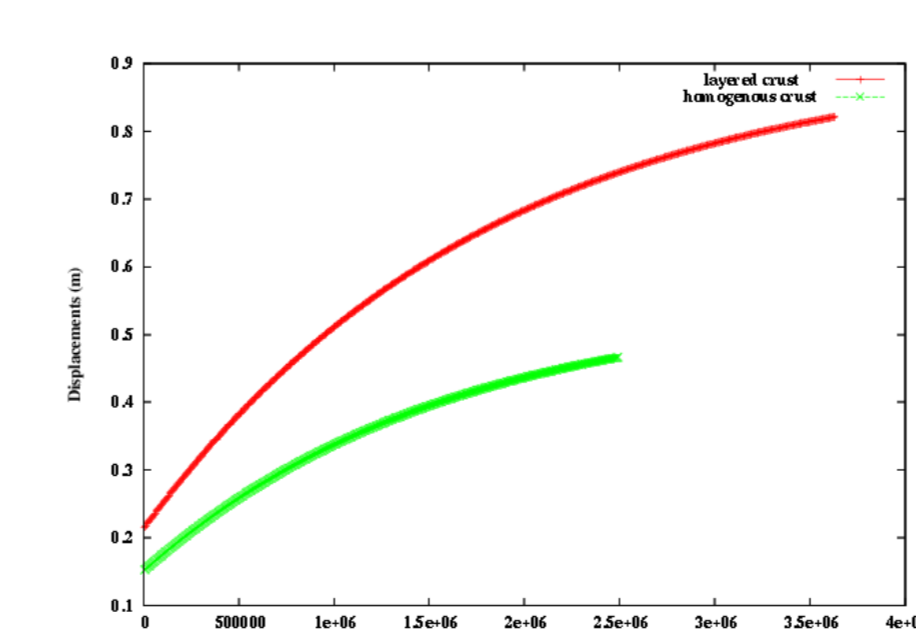

Figure on the left shows the variation of the vertical deformation on time for the homogenous and layered systems (emu: 0.6).

Figure on the right presents the variation of the vertical deformation on time for the 3 layered systems. When the shear ratio increases the behaviour of the system is close to Maxwell model.

Final remarks

The possibilities of continuous GPS monitoring of hazardous fault systems are increasing. The readings will become more precise with the deployment of the new Galileo system. This will open the way to measure the surface displacements with higher precision.

These observations can be supported by simulations such as those presented above in order to help to search for "dangerous" regions.